

LED Brick Star provides a safe, attractive and affordable way to light stairs, aisles, paths and entrance ways.

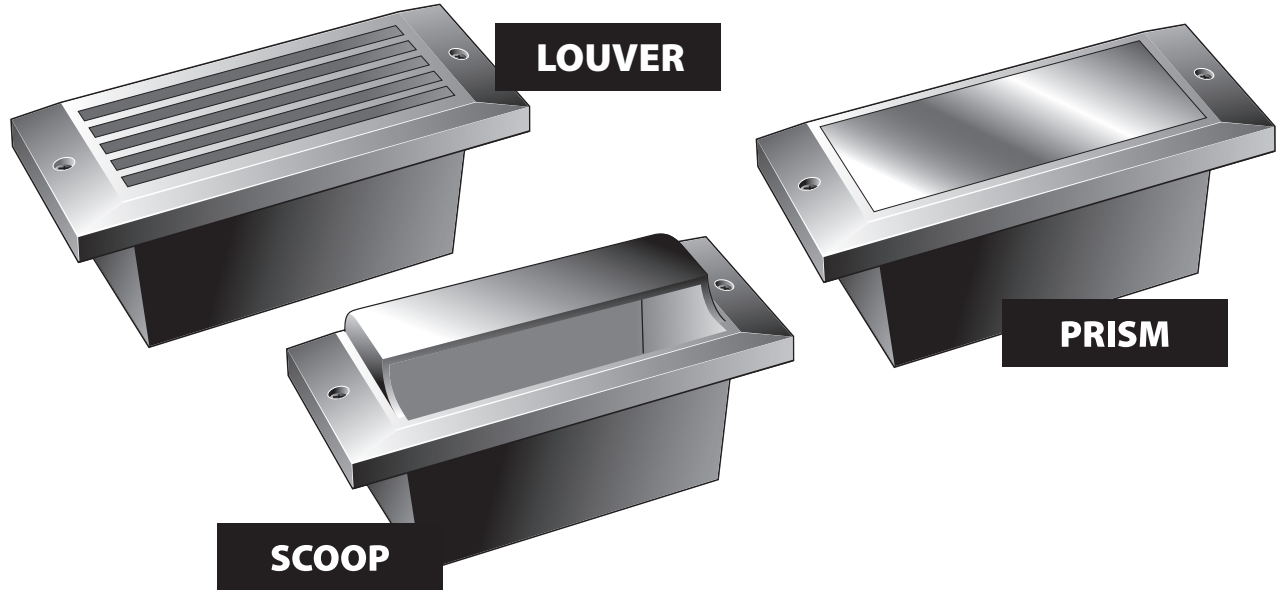

Features

- 40,000-hour LED life
- Ultra low 5.2 watt energy usage per fixture
- CRI 80+
- Lumen output: 468LM
- 120VAC power input
- Up to 150 LED Brick Star lights per 120VAC tap
- Die cast aluminum can and cover
- Available in fluorocarbon can with stainless steel louvre cover
- Fits into any standard brick, or in any void sized 73/4" x 21/2" x 31/4" (196.6mm x 63.5mm x 82.6mm)
- cETLus listed for indoor and outdoor applications including wet, IC, concrete pour, ceiling and shower locations
- Dimmable with most forward phase TRIAC dimming systems
- 3 year limited warranty

Specifications

LED Color	White (3000K +/-200)
Input Voltage	120V AC
Power Consumption (W)	5.2 Watts
Lumen Output	468LM
Can Finish	Powder Coated White, Fluorocarbon Lacquer (Stainless Steel)
CRI	80+
Life Span (hours)	40,000
Lens	Frosted tempered glass
Wiring Options	Up to 150 LED Brick Star lights per 120VAC tap
Approvals	cETLus listed for wet and IC locations

Ordering Code

LBR - II - - WH -

Cover Option Finish Color

L = Louver WH = White
P = Prism BK = Black
S = Scoop BZ = Bronze
 SS = Stainless Steel*

**Available for Louver option only*

Project		Type	
Date		Contact	
Notes			

LED Brick Star Gen II

LED Brick Star provides a safe, attractive and affordable way to light stairs, aisles, paths and entrance ways.

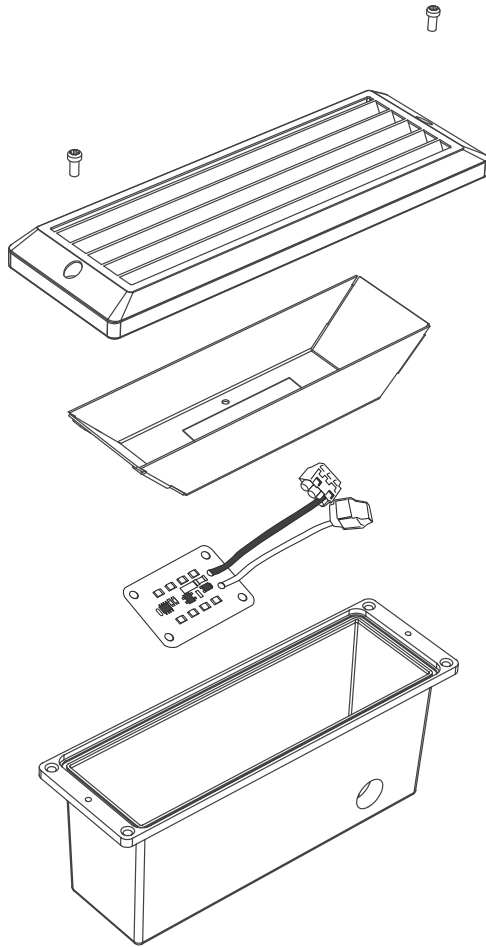

NOTE: for concrete installations,
please use the concrete cap BL-CC

